

3121000155

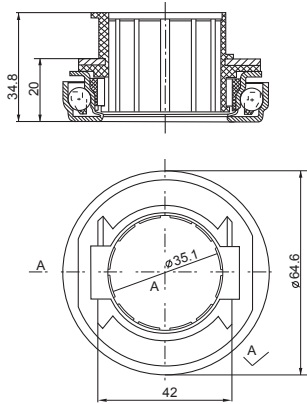

3151089001

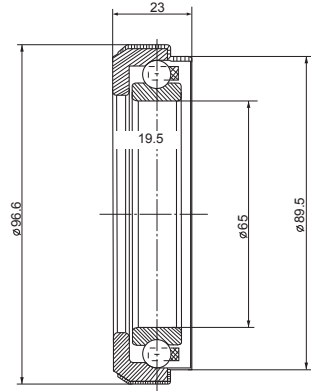

3210-2RSTN

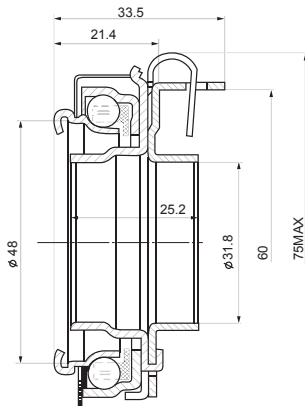

41421-36000

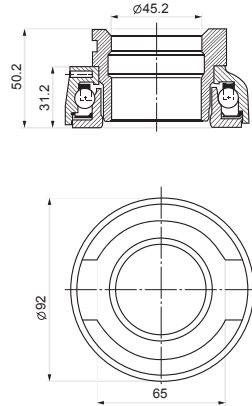

456931

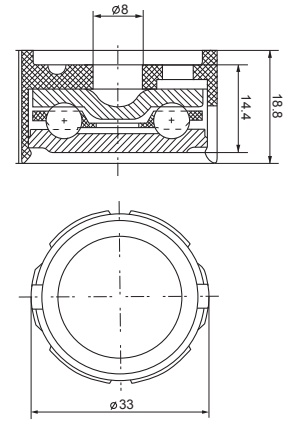

614075

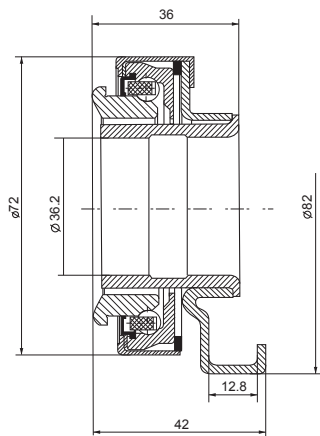

FCR54462-2E

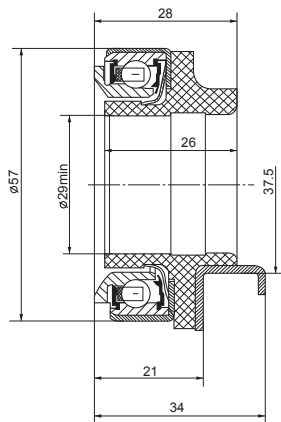

CBU472921C

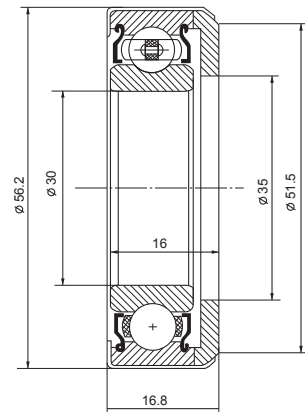

CT-20

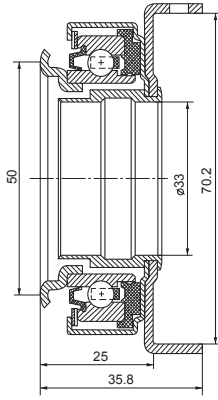

RCTS338A4

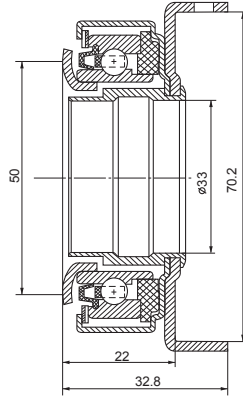

RCT338SA1

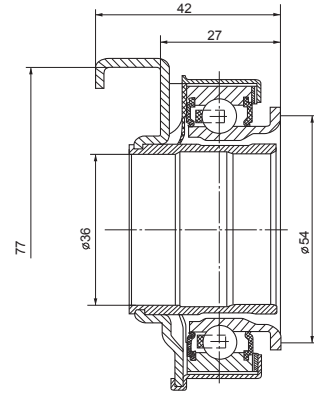

RCT363SA

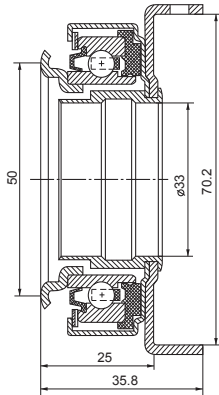

RCTS338SA4

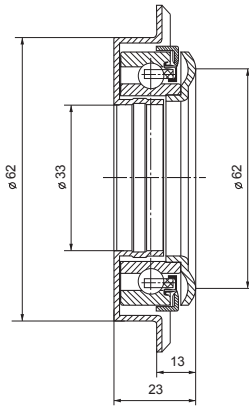

RCTS33SA-1

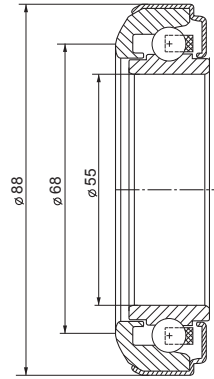

RCT55SA

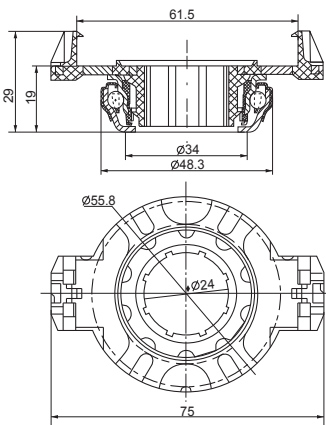

VKC2516

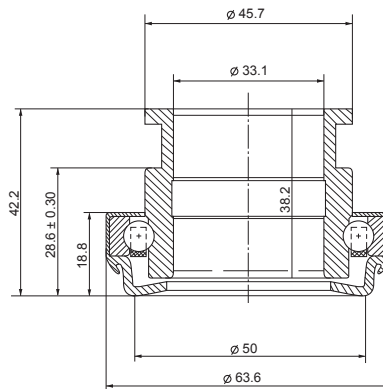

VKC2130

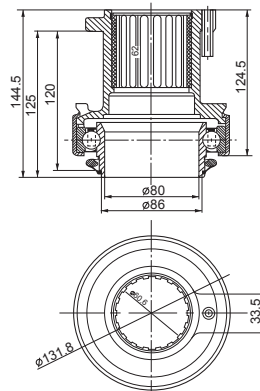

618521

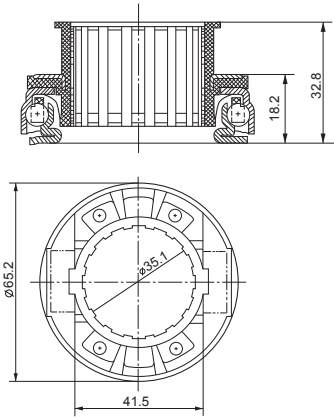

F-206071.6

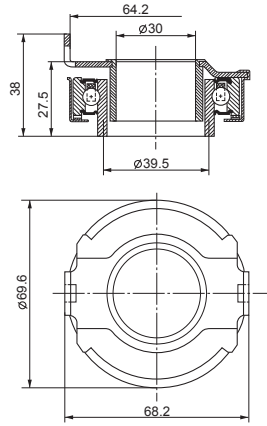

RN-23

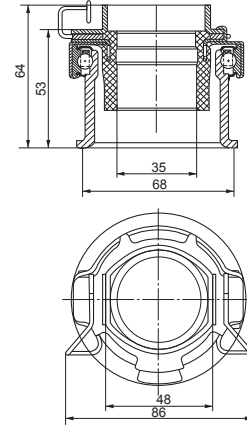

68SCRN63

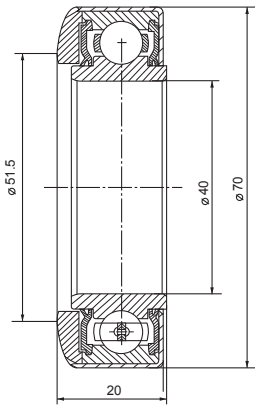

614048

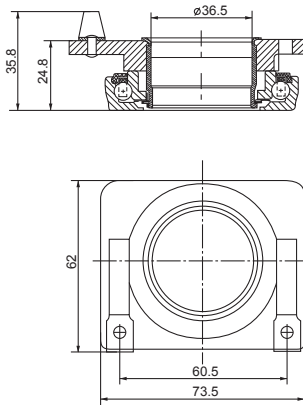

614034

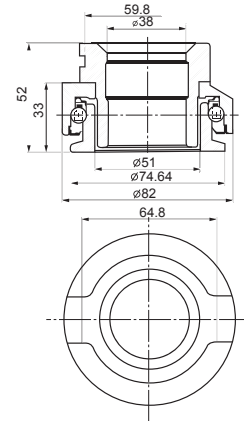

FAHR9439

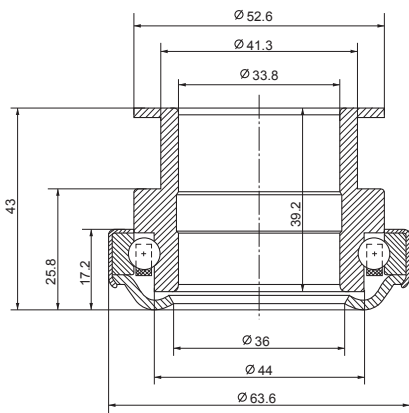

FD-59

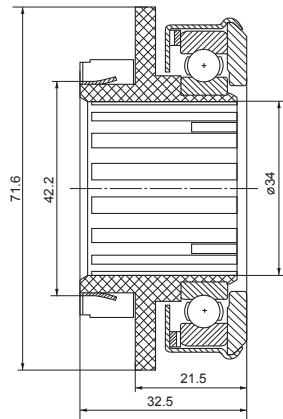

FD-61

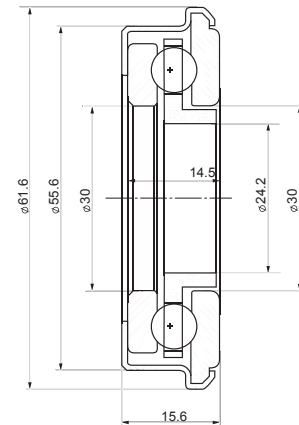

FT-32

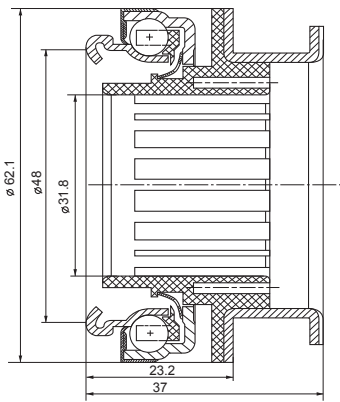

41421-28000

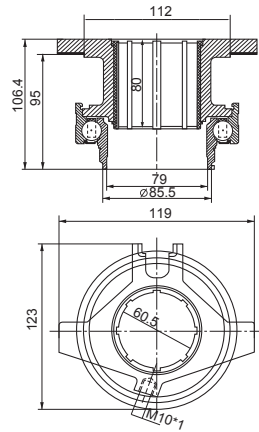

343151224201

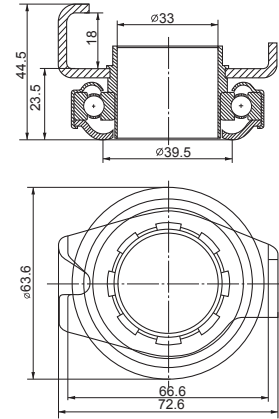

RB9568

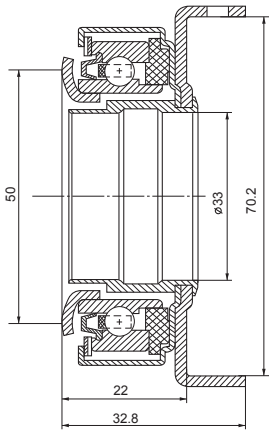

RCTS338SA1

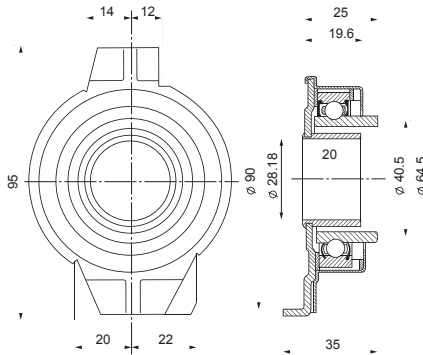

CB010

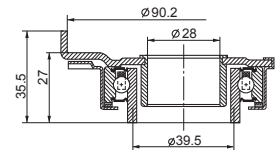

616050

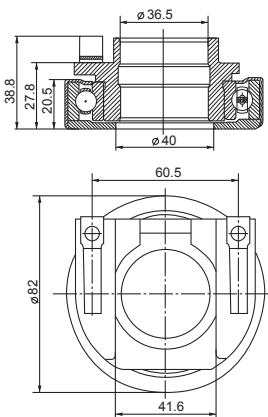
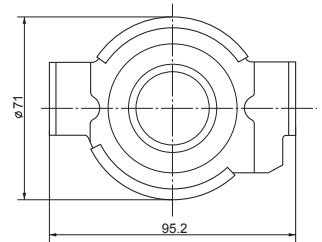

FD-52

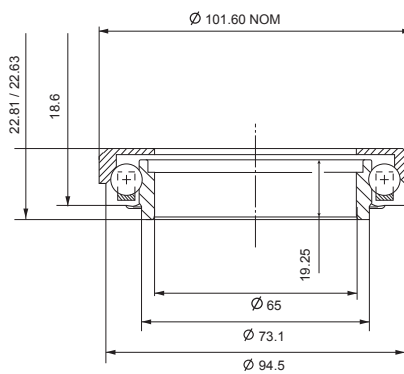

X105-L0520

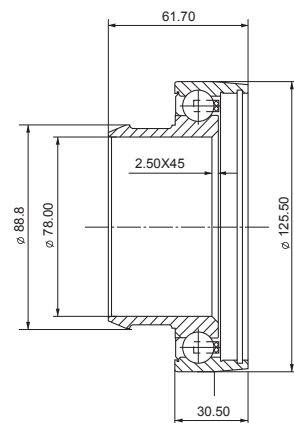

X015-L4017

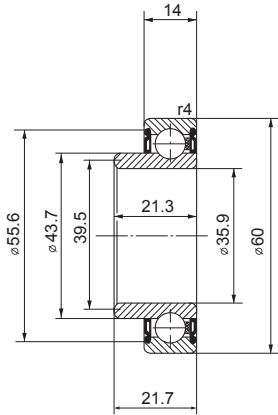

4409360X

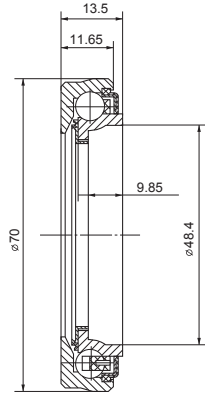

WCT3742F2-01

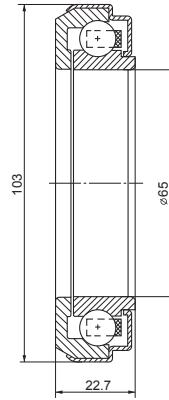

65TKN20

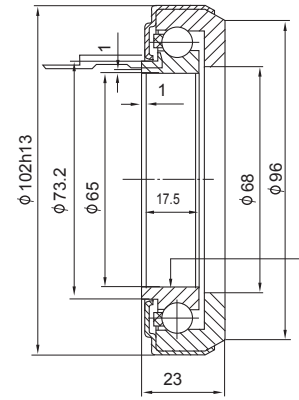

986813

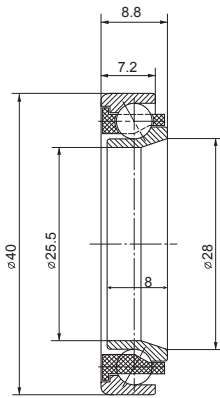

B2540

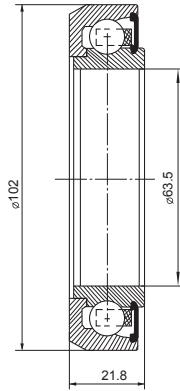

CT1310RS

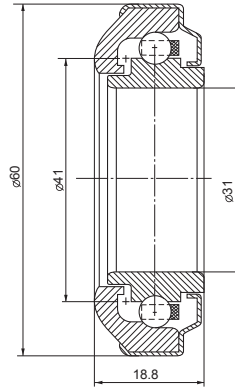

TK31F

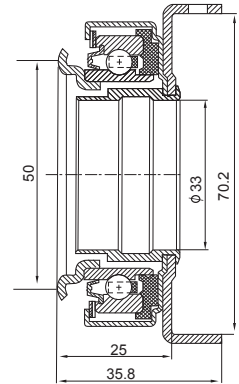

RCTS338SA

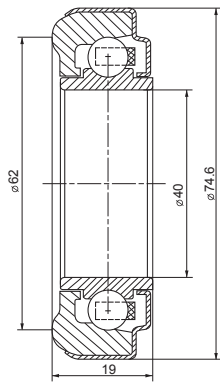

RCT4075-1S

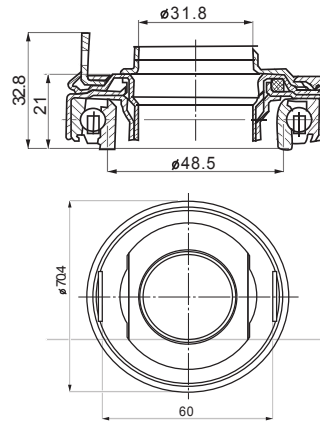

TK52Z-1B

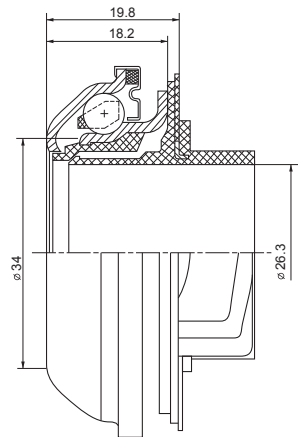

VKC2191

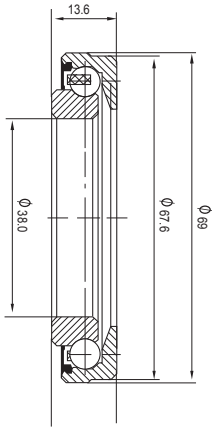

CB036

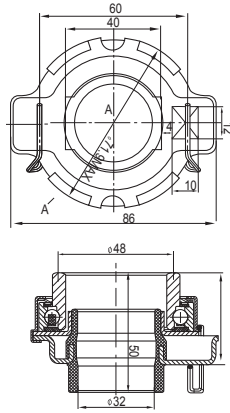

48TKB3201

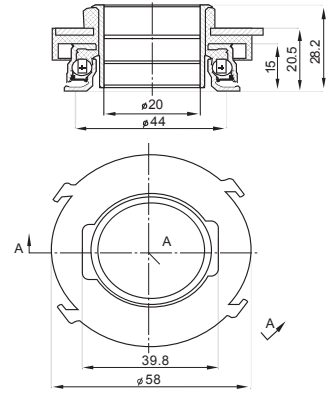

VKC3673

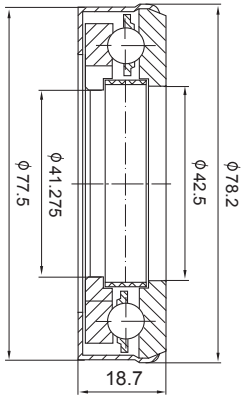

M202

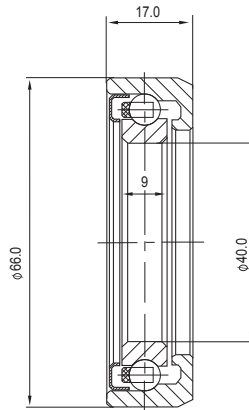

360708K3

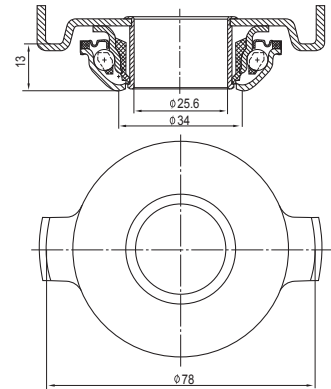

VKC2535

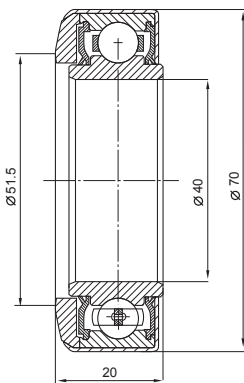

TK40-16A

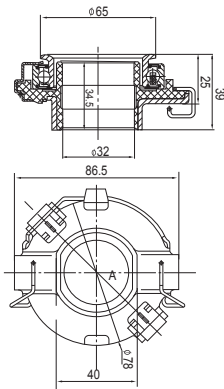

60RCT3225F0

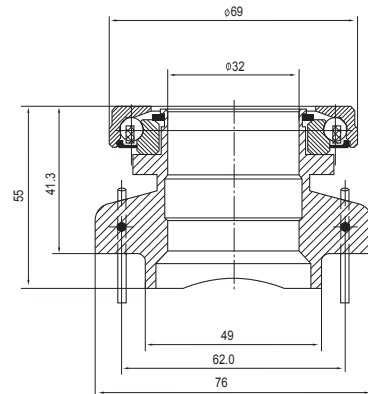

CBDU036

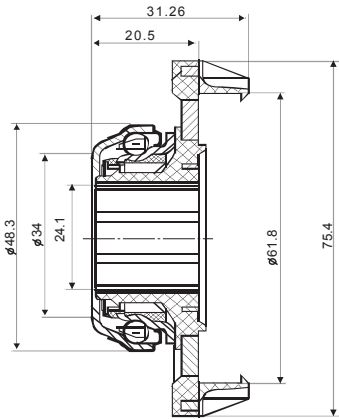

VKC2216

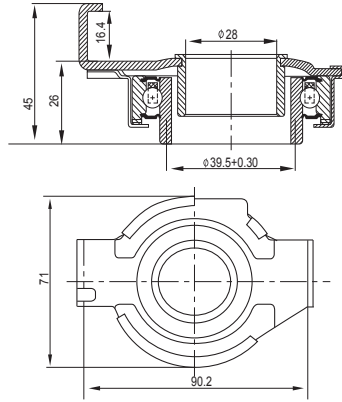

VKC2168

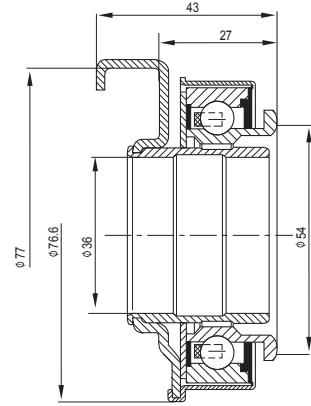

VKC3507

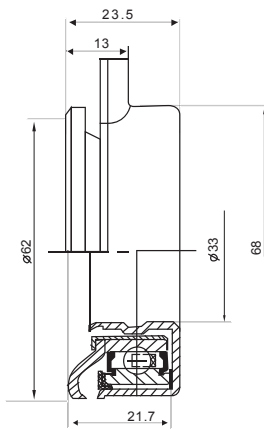

VKC3560

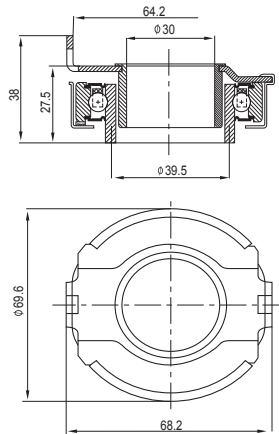

VKC2115

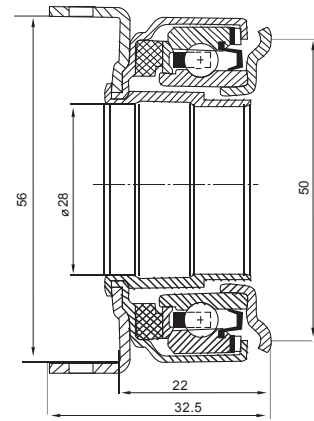

VKC3623

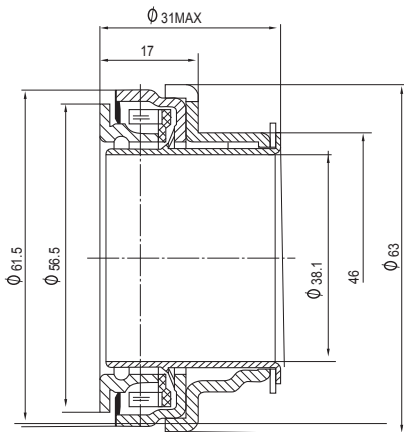

VKC2238

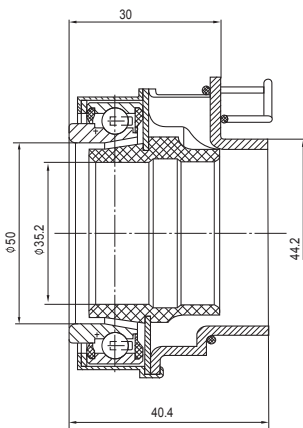

614000

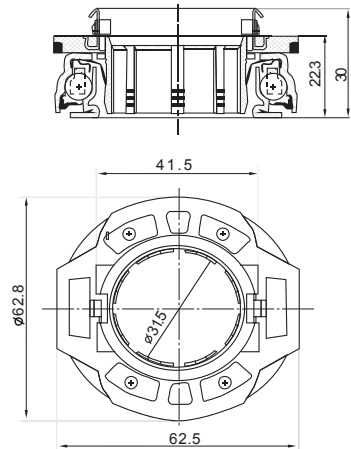

VKC2241

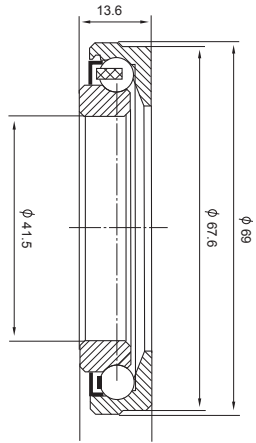

CB040

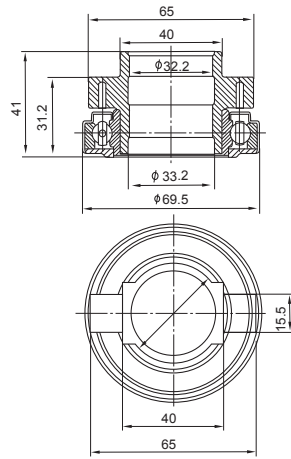

CB2113

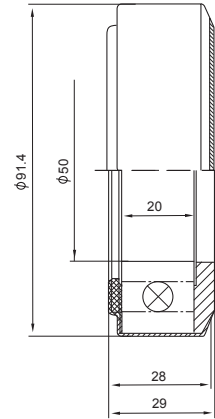

CB2105

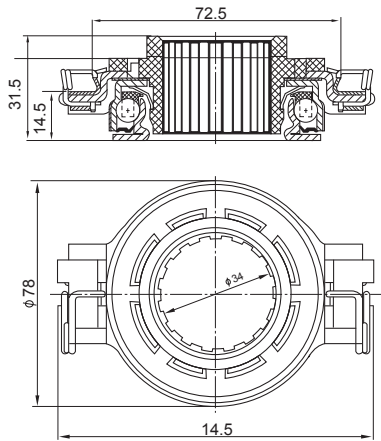

VKC2091

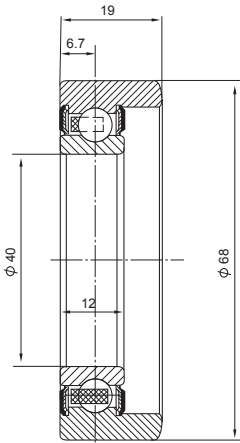

CB2114

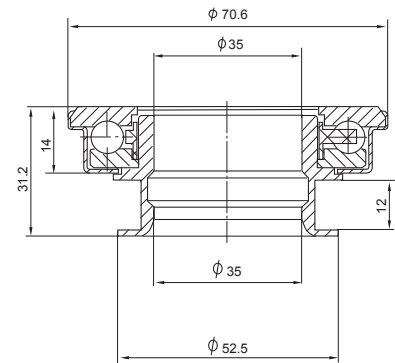

CB2112

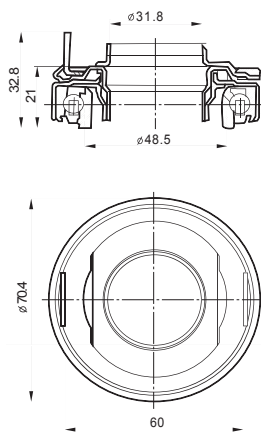

6141261

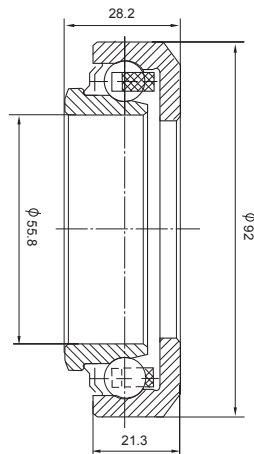

CB2115

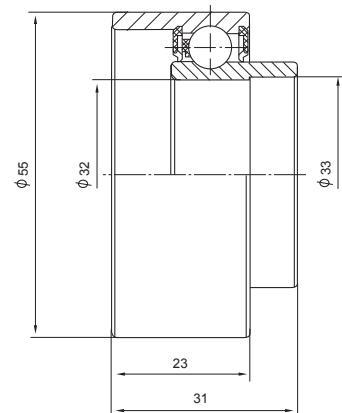

CB2316

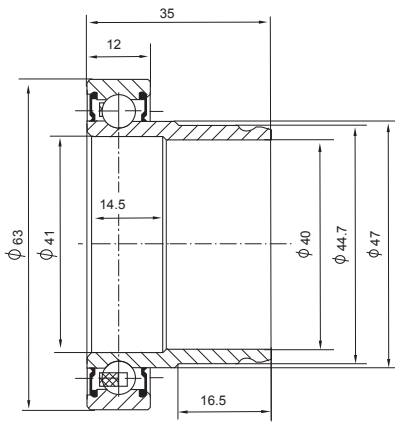

CB2317

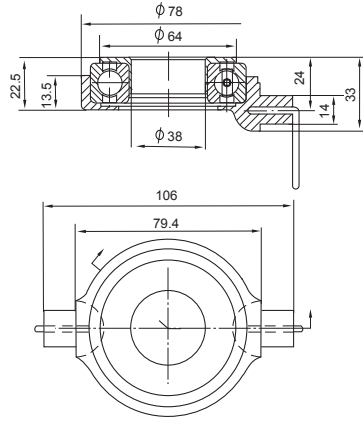

CB6008

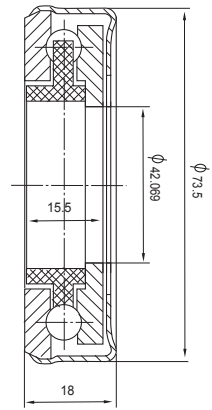

M201

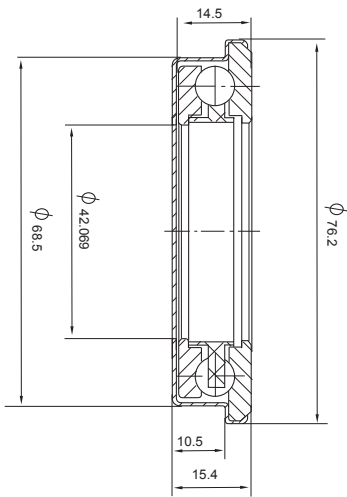

M203

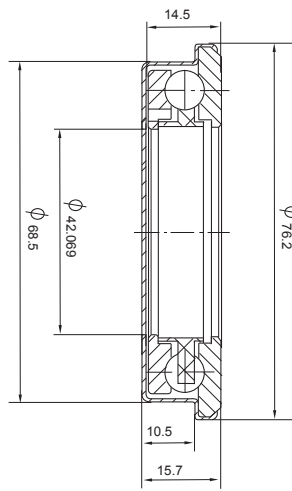

M204

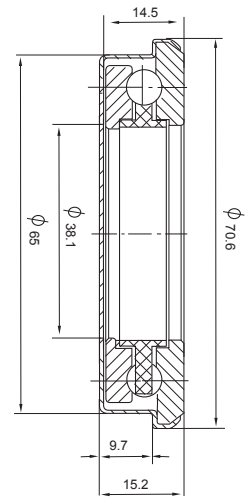

M205

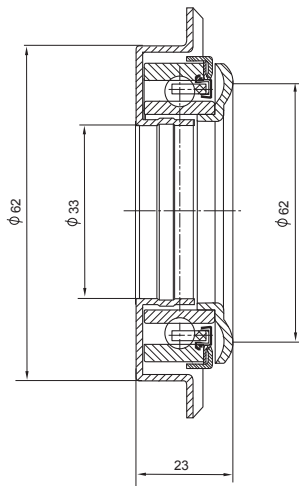

VKC2238

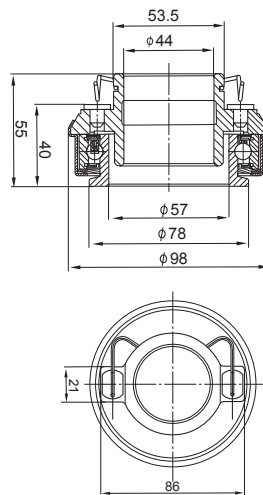

62CT4440F2

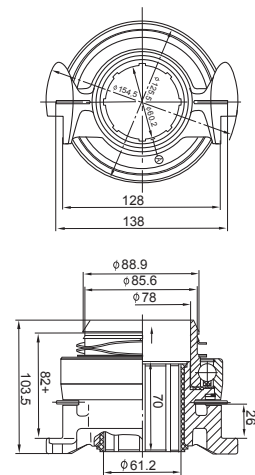

86NL6082F0

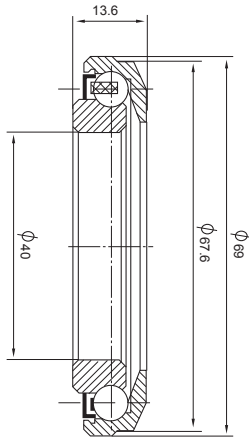

CB037

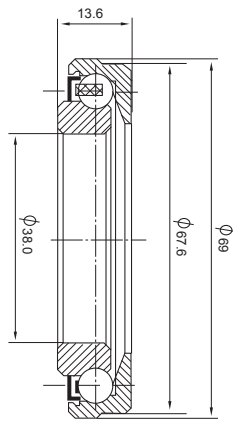

CB038

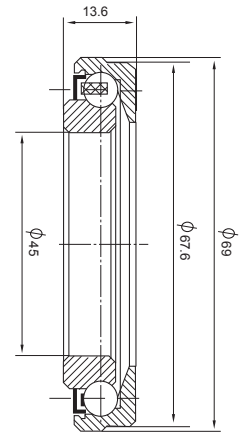

CB039

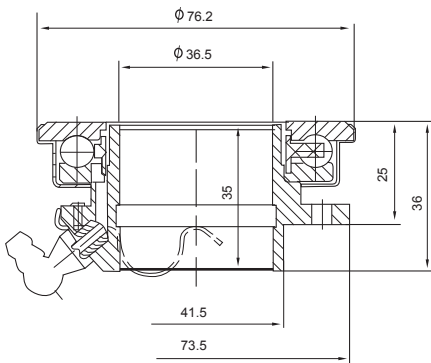

CB2101

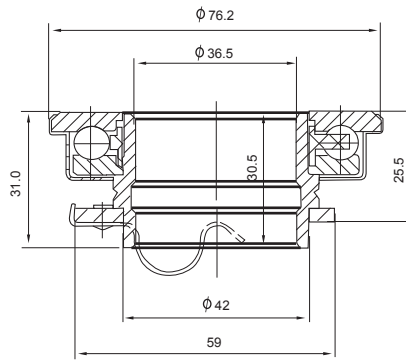

CB2102

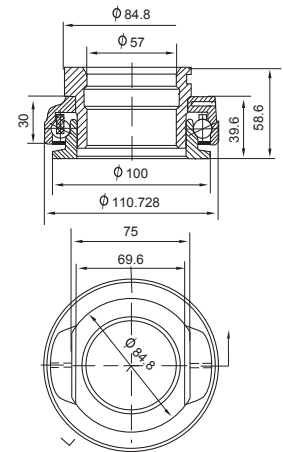

CB2103

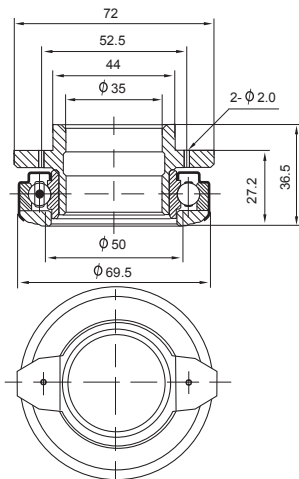

CB2106

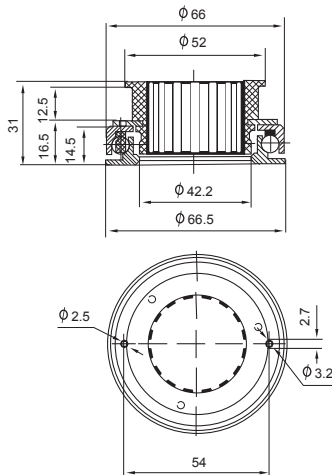

CB2107

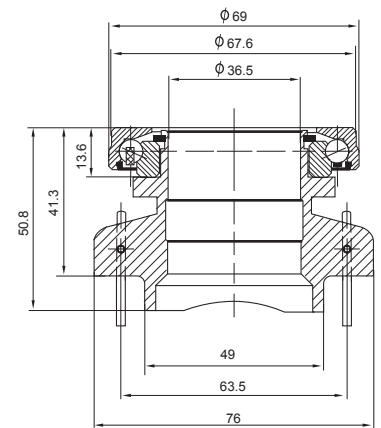

CBDU2108

Clutch Release Bearings

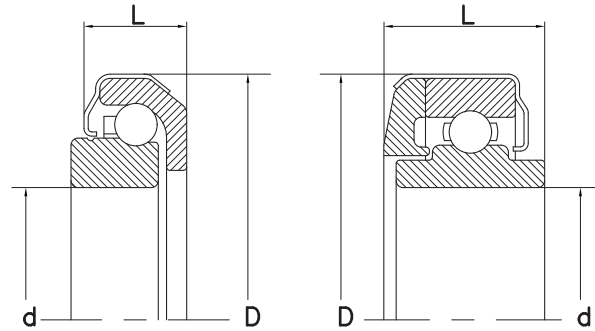

KML No.	Boundary dimensions (mm)		
	d	D	L
01296	33	60	15
01496	38.1	64	16.5
01573	40	67	18.5
01576	40	73.4	19
613001	35	58	14.12
613002	39.99	64.26	18.34
613004	63.5	103.38	20.7
613006	35	63.58	18.39
613008	52.39	87.3	26.25
613009	55	87.6	19.55
613010	39.99	63.83	20.14
613011	65	102.5	22
613012	42	77	19
613013	55	88	16
613016	65.5	102	22
614078	36.9	65.9	20.7
24TK308B2	38.1	67	16.4
24TK308EK	38.1	67	15.88
3W2-1/2	63.5	103.4	21.7
35TMK29KR	35	57	15
40TKD07	40	67.1	20
40TMK29	40	63.6	14
40TNK20	40	70.5	18
45TKD07	45	76.5	23
45TMK29	45	70.5	14

KML No.	Boundary dimensions (mm)		
	d	D	L
52TKD01	52.4	96	26
52TMK804	52.4	94	20
65TNK20/2E	65	102	22
CT1310A	63.5	103	21.5
CT45F	45	74	17.5
CT52A-1	52.4	97	20
CT55BL1	55	87.5	19.5
CT708L1	70	117	27
CT70B	70	117	27
FC1723C	45	73.6	18
RCT30482RS	30	48	13
RCT3558ARUS	35	58	14
RCT40	40	70	20
RCT4064S	40	63.5	16
RCTS225SA4	35	72	44.3
TK31F	31	57.4	18.8
TK33Z-1	33	58.42	17
TK34Z-2	34.942	71.6	47.625
TK40-14A	40	63.8	16
TK40-16A	40	70	20
TK40-4A	40	74.5	19
TK45-15U3	45	76.5	23
TK45-4A	45	73.5	18
TK45-4B	45	73.6	18
TK52Z-1	52.4	94	20



Clutch Release Bearings

Self-aligning

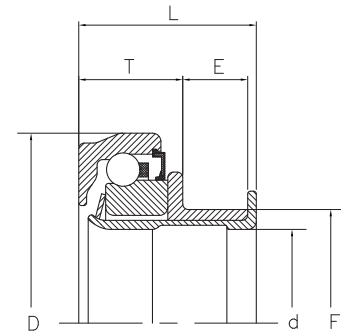

KML No.	Boundary dimensions (mm)					
	d	D	L	E	T	F
614007	30.23	70.1	30.18		18.64	57.5
614009	35	70.1	27.64	9.7	16.1	41.28
614013	33.78	70.1	34.60	15.24	17.27	42.5
614014	36.53	70.1	34.54	15.24	17.27	42.5
614016	31.75	67.31	39.73		32	45.95
614018	34.98	69	31.65	12.8	16.8	41.27
614022	33.08	90	23		13	67.9
614026	33.07	80.62	40.26	11.99	25	77.29
614031	31.04	63.83	35.71		23.01	53.16
614033	29	57	31		21	47
614036	31.81	77.71	51.94		41.3	49.1
614037	34.93	67.05	48.23	12.8	31.75	41.27
614038	36.51	73.66	36.55		24.8	60.45
614043	33	74.15	28.45		22	70.23
614044	31.75	70.4	43		35.5	45.9
614047	33.08	90	23		13	67.9
614050	28.05	62.51	32		23	55.15
614053	31.75	71.88	34.49		27	45.85
614054	31.81	77.72	55.56		41.28	49.11
614056	33.19	73.7	35		25	70.5
614059	33.15	80.01	32		23.01	68.4
614067	36.11	81.46	42.37	11.99	27	77.29
614077	31.115	69.85	38.61		26.29	53.213
614082	28.067	59.69	31.877		21.844	30.28
614083	34.99	70.36	30.7	12.1	16.51	41.28
614084	35.64	83.95	33.909		24.92	79.375
614086	35	76	40.5		30	44
614093	36.45	77.72	51		41.28	49.2
614107	37	90	43		31	56
614108	31.8	77.47	24.61		17.37	55.7
614110	28	57.15	27.5		22.51	41
614126	31.78	70.49	33.83		21.1	60
614128	29.26	62.84	33.78	11	21	38
614145	28.19	57	29		22.5	45
614152	33	81	31	16.69	22	79.25
RCT359SA9	35	75	33.8			
RCT45-1S	45	73.6	18			

Self-aligning

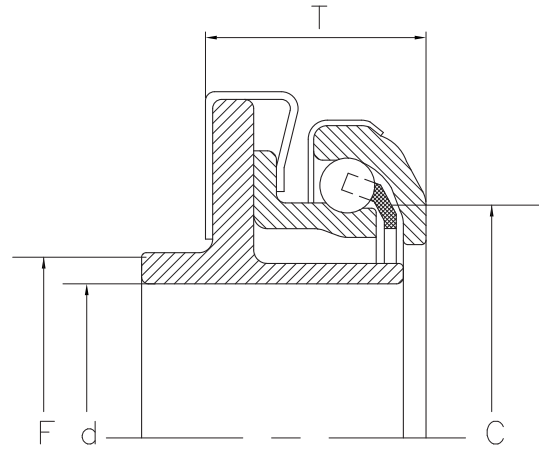

KML No.	Boundary dimensions (mm)			
	d	C	T	F
VKC2191	26	34	29.8	19.6
VKC2216	24	34	61.4	20.5
VKC2051	33	39.5	66	24
614108	31.8	63	17.37	24.61
44TKB2805R	28.5	43	22	34
614108	31.8	77.47	24.61	

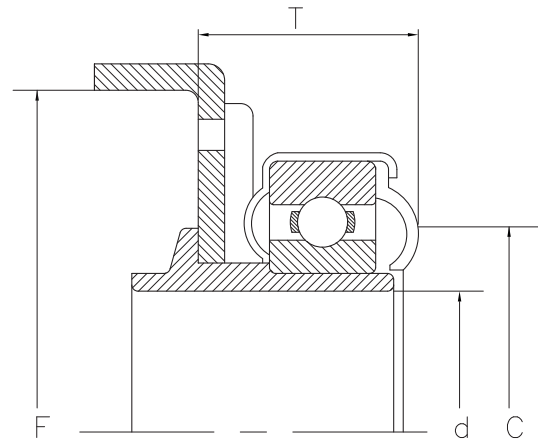

KML No.	Boundary dimensions (mm)			
	d	C	T	F
614126	31.78		21.1	60.13
VKC2168	28.5	38.7	18.6	90.7
VKC3507	36	54	27	77
VKC3568	33	50	25	77
VKC3600	36	54	24	77
VKC3654	31	47	23	68



Self-aligning

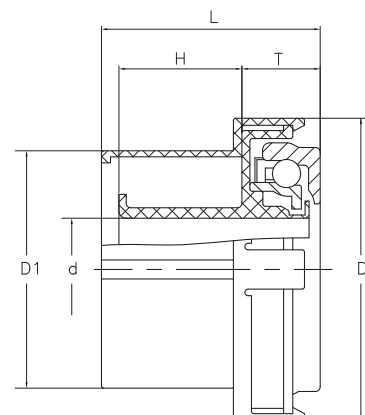

KML No.	Boundary dimensions (mm)						SKF CR NO.	Green NO.	Koyo NO.	A-1 NO.	Mass Kg
	d	D	D1	L	T	H					
K614040	36.76	80	66.2	58.7	16.9	37.6	N4035	CB2126C	CT362SA	B49815C	0.22
K614061	36.76	80	66.2	60.4	16.4	40.2	N4061	CB1698C		B49836	0.22

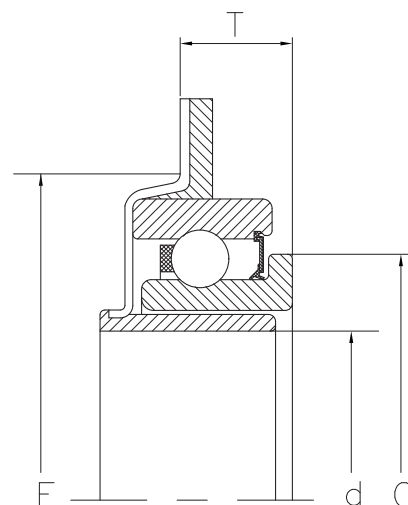

KML No.	Boundary dimensions (mm)			
	d	C	T	F
VKC2091	34	52.5	13.2	72
VKC3551	28	38	10	62
VKC3560	33	62	13	68
VKC3581	33	62	20	68
VKC3598	33	62	18	68
VKC3610	33	62	24	68
VKC3611	33	48	22	68
VKC3641	33	62	16	68